

Consistent Flavor Every Time

Automated process eliminates human variation
Complete 6kg of rice mixed with vinegar
absorbed and cooled in 5 minutes



Compact & High-Performance Best Rice & Vinegar Mixer

Small footprint design ideal for sushi shops and small kitchens, energy-saving and space-saving, size of a rice cooker, approximately 0.11m³

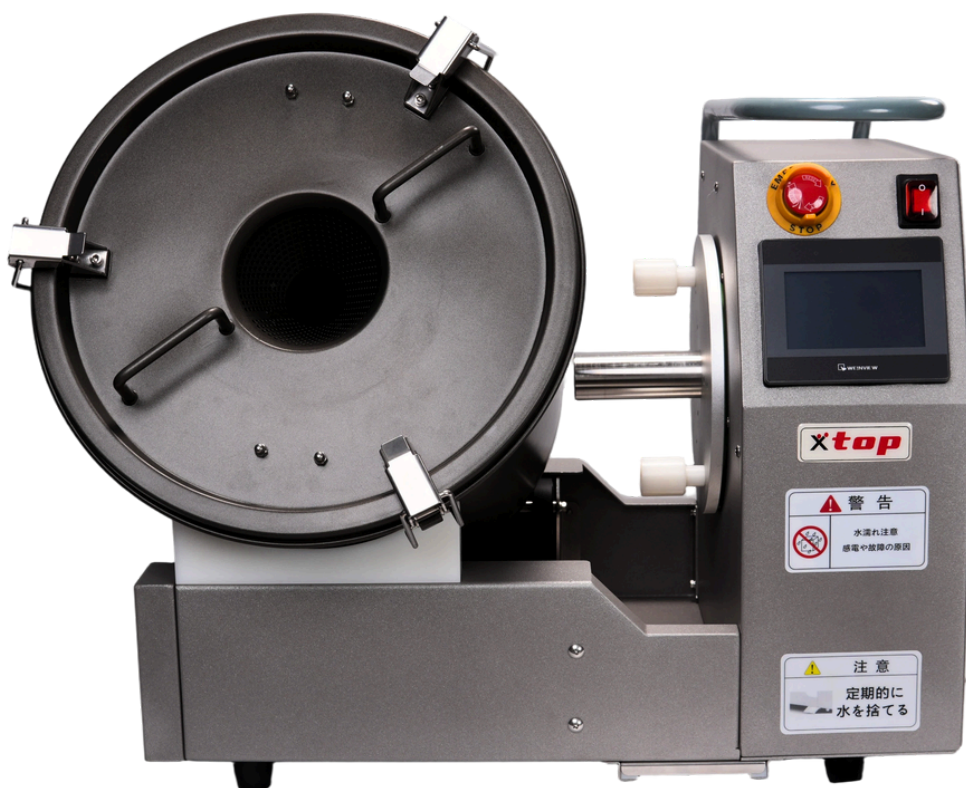

Mix the measured amount of
rice and Vinegar

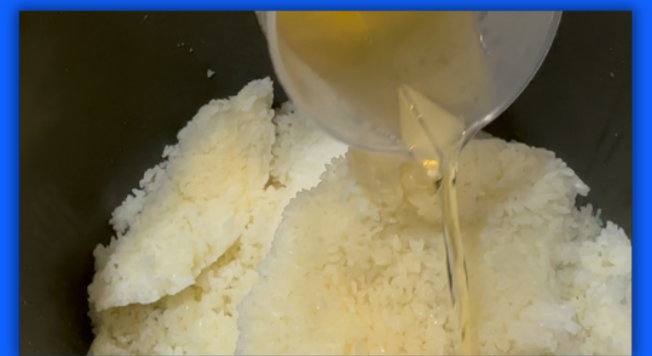

Put the Container back to the
machine and start running

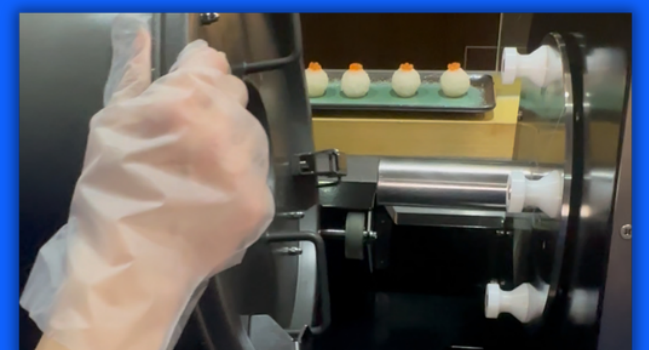



SINCE 1993

SPECIFICATION

Specifications:

Model

TSM-S2

Input

AC100-240V

Power Consumption

90W

Capacity

6kg

Operating Time

3-8 minutes

Weight

30kg

Machine dimensions (in mm)

Width: 560mm

Depth: 400mm

Height: 480mm

Patent:

CN201630567103.6

CN201621310218.8

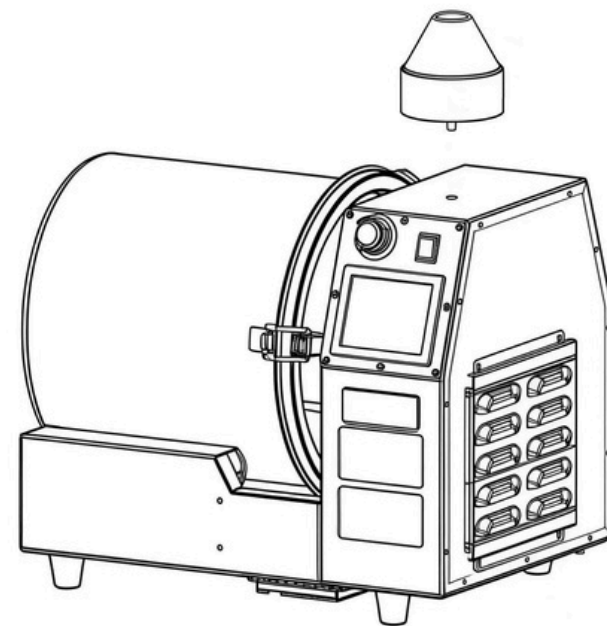
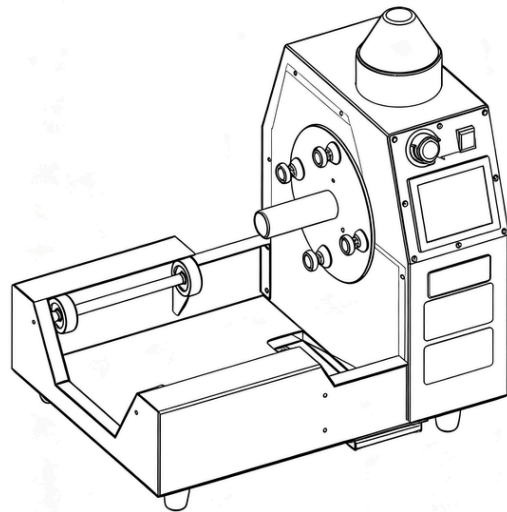
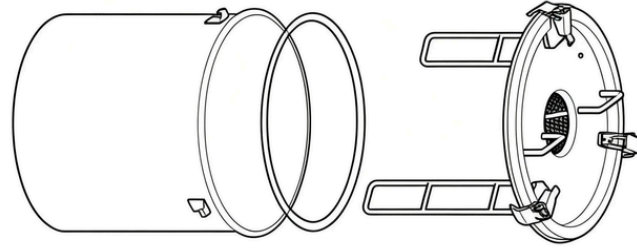

FEATURE

- **6kg Rice Capacity**

Handles up to 6kg cooked rice per batch for efficient operation

- **Integrated Mixing & Cooling Function**

Simultaneously mixes rice and vinegar while cooling for optimal sushi texture

- **Multiple Operation Modes**

Preset 3 different MODEs, CUSTOM programs, and Manual Mode for flexible operation

- **Precision Time Adjustment**

Adjust mixing, resting and cooling duration easily

- **Touchscreen Control Interface**

Simple and intuitive control panel operation

- **Multi-Language Interface**

Supports multiple languages for global operation

- **Automatic Safety Stop Protection**

Machine stops immediately when safety cover is removed

- **Food-Grade Anti-Stick System**

Special plant oil application ensures smooth and non-sticky operation

TSM-S2 SUSHI RICE & VINEGAR MIXER

AFTER-SALES SUPPORT

Two Year Warranty

24/7 Technical Support

Lifetime Maintenance

Spare parts replacement

CONTACT US

Tel: +61 485 590 361

Email: sanheaustralia@outlook.com

Website: www.conveyor-sushi.com

Address: 10 Harrow Ct,

Doncaster, VIC, 3108, Australia