



# TSM-R1-S

Sushi Rice Sheeter

## One Touch, Two Sheets Six Sizes Option

Soft and perfectly formed every time, delivering standardized results with absolute consistency and zero variation



## Double the Sheets

Double the speed

With our optional extend long table, the machine produce double rice sheets in a single run – faster production, less labor, high efficiency



### Single Sheet Mode



### Double Sheet Mode





SINCE 1993

## SPECIFICATION

### Specifications:

#### Model

TSM-R1

#### Input

AC100-240V

#### Power Consumption

200W

#### Capacity

600-800 Sheets / hour

#### Hopper capacity

7.5kg

#### Weight

40kg

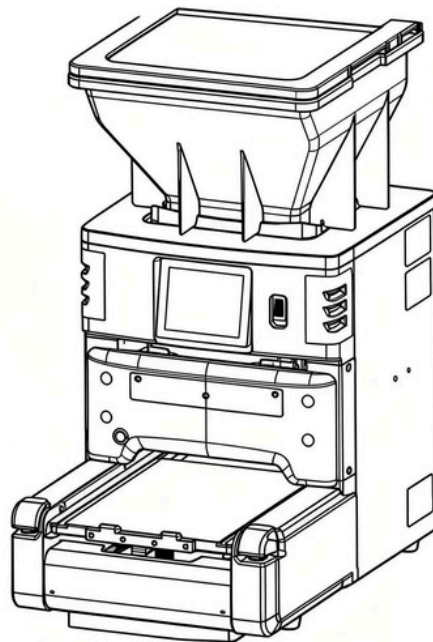
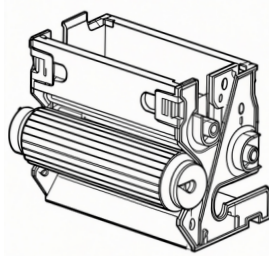
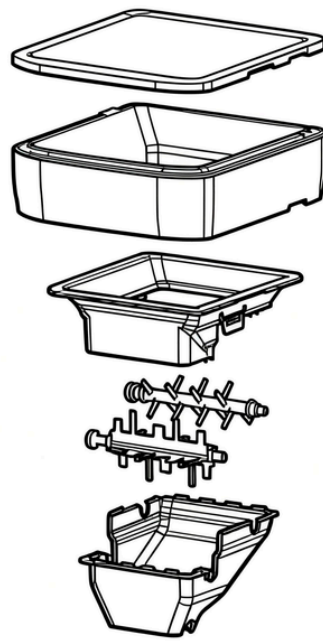

## FEATURE

- **Adjustable Length & Thickness System**  
Length adjustable from 60–420mm and thickness from 1–10mm with 0.5mm precision
- **Customizable Density Control**  
Density level from -8 to +8 to suit different rice types and textures
- **Single & Double Output Modes**  
Flexible production for single or continuous double rice sheet operation
- **Smart Sensor Feeding System**  
Low-level rice sensor and sheet detection sensor ensure stable feeding and precise timing
- **Built-in Rice Warmer (60°C)**  
Maintains optimal rice temperature for consistent texture
- **Touchscreen Control Interface**  
Intuitive display with 6 programmable memory presets
- **Multi-Language Support**  
User-friendly interface for global operation
- **Automatic Safety Stop Protection**  
Machine stops immediately when safety cover is removed

# TSM-R1-S SUSHI RICE SHEETER

## AFTER-SALES SUPPORT

Two Year Warranty  
24/7 Technical Support  
Lifetime Maintenance  
Spare parts replacement

## CONTACT US

Tel: +61 485 590 361  
Email: [sanheaustralia@outlook.com](mailto:sanheaustralia@outlook.com)  
Website: [www.conveyor-sushi.com](http://www.conveyor-sushi.com)  
Address: 10 Harrow Ct,  
Doncaster, VIC, 3108, Australia