

# MILLIVOLT GAS FRYERS

SG14-2/FD



For high production gas economy frying, specify Pitco Solstice gas tube fryers with the patented Solstice Burner Technology. These dependable millivolt fryers feature a blower-free atmospheric heating system that provides fast recovery to cook a variety of food products. The Solstice gas fryer comes standard with a millivolt thermostat with a thermo-safety pilot and high temperature safety limit switch. The unique Solstice burner and baffle design increases cooking production, lowers flue temperature, and improves the working environment compared to previous models.

## STANDARD FRYER FEATURES & ACCESSORIES

- Tank - stainless steel construction
- Cabinet - stainless front, door and sides
- Solstice Burner Technology, No blower or ceramics
- Millivolt Thermostat (T-Stat) 95°C-200°C CE
- Thermo-Safety pilot with built in regulator
- High Temperature safety limit switch
- Heavy duty 3/16" bottom door hinge
- 1 ¼" (32 mm) Full port drain valve for fast draining
- Separate Manual gas shutoffs, for front servicing
- Integrated flue deflector
- 9" (229 mm) swivel castors with front brakes
- Tube rack, allows crumbs & debris into cool zone
- Removable basket hanger, requires no tools
- Drain Line Clean out rod and brush
- Drain Extension
- Lids
- Fryer cleaner sample packet
- 2 Baskets per tank

## FRYER FILTER SYSTEM

- Simple two-step filtration
- Fast filtering with a 30L per minute pump for quick oil refills
- Easy, hassle-free hookup with a self-aligning filter connection
- Rear oil return helps clean the fryer bottom
- Durable stainless steel filter pan with rear wheels for easy movement
- Convenient self-storing lid stays out of the way
- Comes standard with washdown/discharge hose



Millivolt Thermostat



Please note, due to ongoing product development and improvement, we reserve the right to change product design and specification at any time without notice.



**HEAD OFFICE  
AND MANUFACTURING PLANT**  
211-217 Woodpark Road  
Smithfield NSW 2164

**VIC - TAS**  
47 Stubbs Street,  
Kensington  
VIC 3031

**QLD**  
U12, 210 Queensport  
Rd Nth, Murrarie  
QLD 4172

**WA**  
U2, 9 Meares Way,  
Canning Vale WA  
6155

1800 013 123  
+61 2 9604 7333  
sales@middleby.com.au  
middleby.com.au

# MILLIVOLT GAS FRYERS

SG14-2/FD



SPECIFICATIONS	
Dimensions (W x D x H)	794 x 875 x 1172mm
Cooking Area (W x D x H)	356 x 127 x 356mm
Oil Capacity per tank	22 Litres
Rating	238MJ
Weight	200Kg

INSTALLATION CLEARANCES	
Front min.	762mm
Floor min.	152mm
Combustible material - Sides min.	152mm
Combustible material - Rear min.	152mm
Non-Combustible material - Sides min.	0
Non-Combustible material - Rear min.	0
Fryer Flue Area	Do not block / restrict flue gases from flowing into hood or install vent hood drains over the flue.

	GAS SYSTEM REQUIREMENTS	
	NG	LPG
Store Supply Pressure*	17.4 mbars/ 1.7 kPa	27.4 mbars/ 2.7 kPa
Burner Manifold Pressure	10 mbars / 1 kPa	25mbars/ 2.4 kPa

FILTER SPECIFICATIONS	
Voltage/Frequency/Amps	240/50/3.5
Filter pump rated flow	30LPM

Minimum 10amp 240V supply, One plugs required (not included).

\* Check plumbing / gas codes for proper gas supply line sizing to sustain burner pressure when all gas appliances are full on.

**A** Electrical Connection

**B** 3/4" BSP Gas Connection

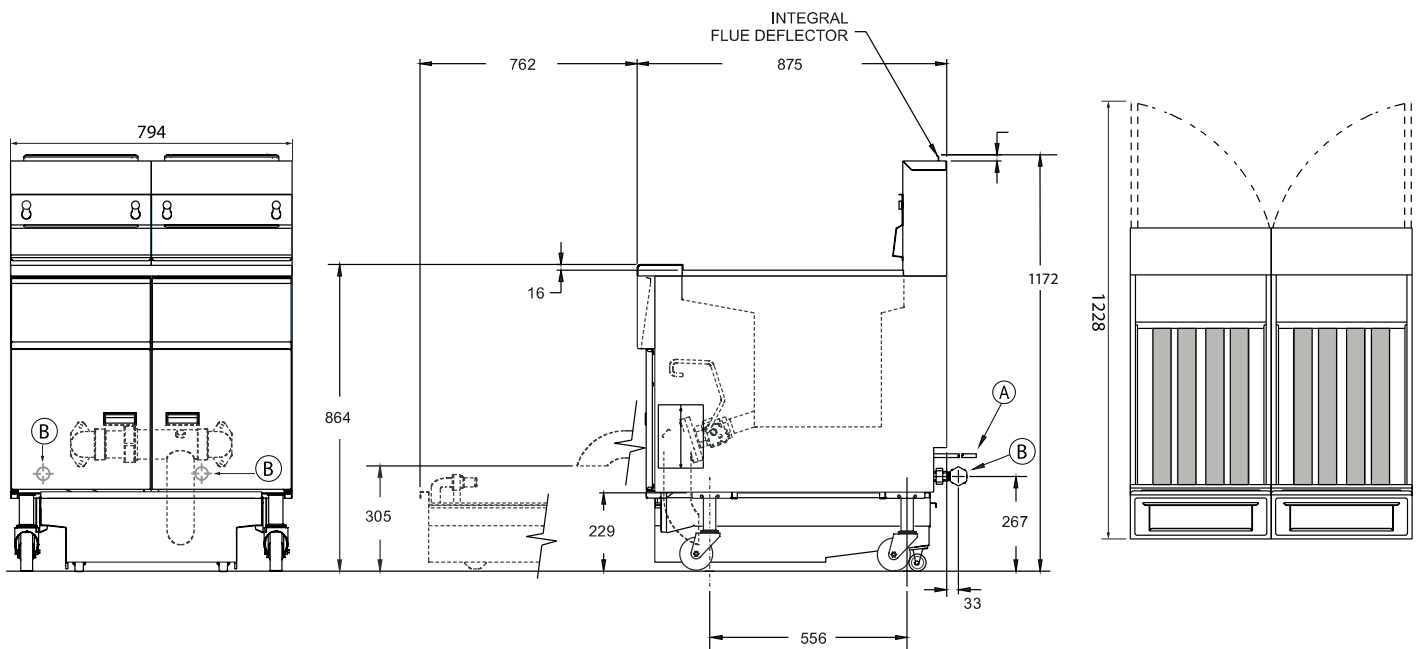

Please note, due to ongoing product development and improvement, we reserve the right to change product design and specification at any time without notice.



**HEAD OFFICE  
AND MANUFACTURING PLANT**  
211-217 Woodpark Road  
Smithfield NSW 2164

**VIC - TAS**  
47 Stubbs Street,  
Kensington  
VIC 3031

**QLD**  
U12, 210 Queensport  
Rd Nth, Murarrie  
QLD 4172

**WA**  
U2, 9 Meares Way,  
Canning Vale WA  
6155

**1800 013 123**  
**+61 2 9604 7333**  
**sales@middleby.com.au**  
**middleby.com.au**