

M3

Rice Dispenser

**Fluffy texture, balanced moisture,
perfect warmth and consistent
quality in every serving**

Our products cover a variety of styles and models, suitable for different sizes and types of food and beverage businesses.



Efficiency-Oriented Premium & Strategic

Five modes can be freely set from 50-400g to meet different user needs. Good insulation and sealing performance, maintaining the rice quality while preventing water evaporation and loss



Add rice in to the Hopper



Customized Rice Amount

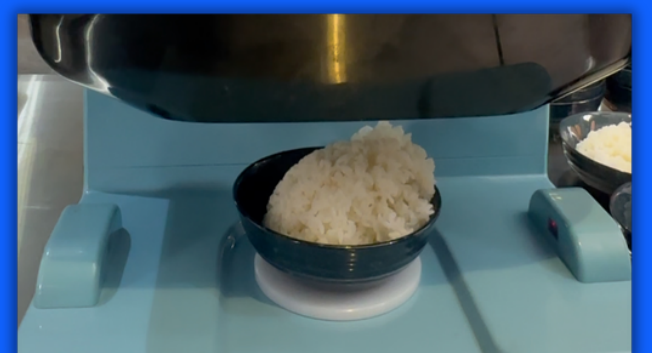



SINCE 1993

SPECIFICATION

Specifications:

Model

M3

Input

AC100-240V

Power Consumption

150W

Capacity

2-3 second / drop

Hopper capacity

10kg

Built-in Warmer

60-70 Degree Celsius

Machine dimensions (in mm)

Width: 540mm

Depth: 450mm

Height: 695mm

Weight

48kg

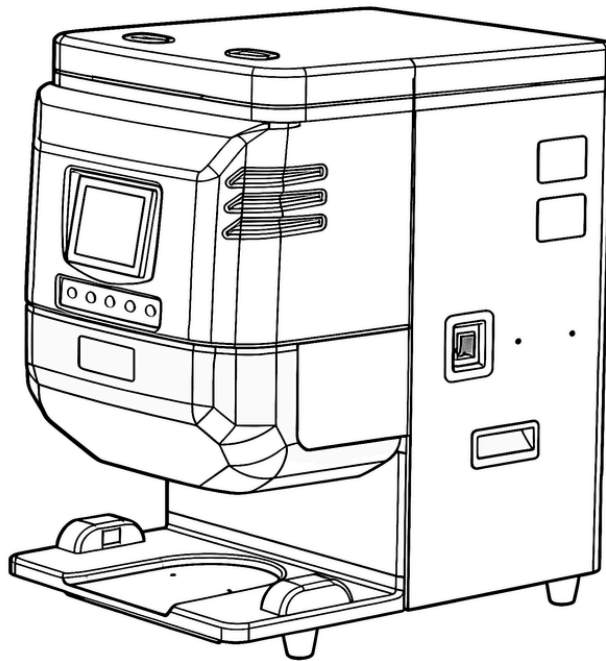
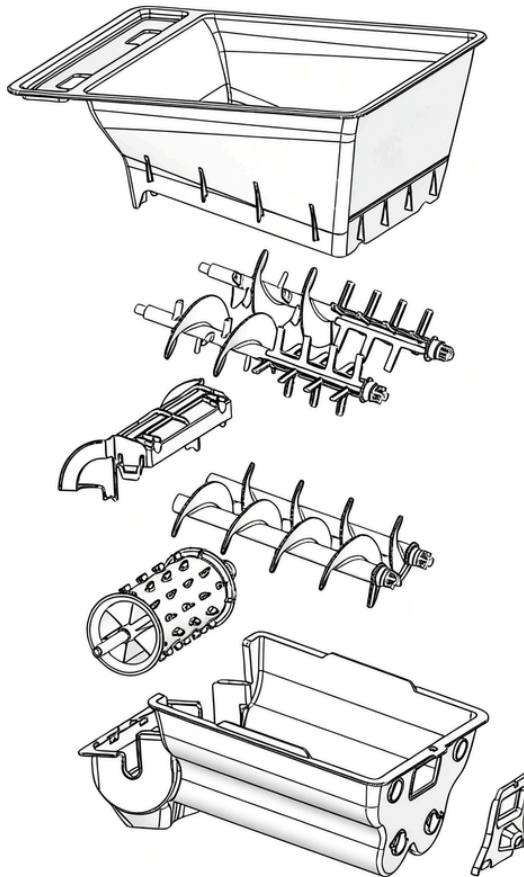

FEATURE

- **High Precision Weight Control**
Adjustable from 50g to 400g for consistent portion accuracy
- **Three Smart Operating Modes**
Normal, Standby (pre-measurement), and Continuous Mode for flexible workflow
- **Smart Rice Feeding Sensor**
Automatically detects low rice level
- **Five Programmable Portion Sizes**
Quick selection of 5 preset serving weights
- **Built-in Rice Warmer (60-70°C)**
Maintains optimal rice temperature for consistent texture
- **Multi-Language Interface**
Supports multiple languages for global operation
- **Production Quantity Tracking**
Displays serving count per weight, total quantity, and total weight
- **Food-Grade Anti-Stick System**
Special plant oil application ensures smooth and non-sticky operation

M3

INTELLIGENT RICE DISPENSER

AFTER-SALES SUPPORT

Two Year Warranty
24/7 Technical Support
Lifetime Maintenance
Spare parts replacement

CONTACT US

Tel: +61 485 590 361

Email: sanheaustralia@outlook.com

Website: www.conveyor-sushi.com

Address: 10 Harrow Ct,
Doncaster, VIC, 3108, Australia